

/ ACCESSORIES



No chipping on
concrete and stone

Better grip through
high traction

Optimum gripping area

The accessories are only available in conjunction with a tooth set

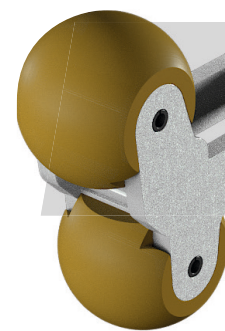

Pipegrip

for pipes, manhole rings,
block steps etc.

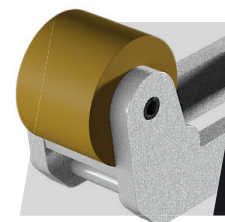

Softgrip

for very smooth surfaces
e.g. polished granite

Assembly in under one minute!

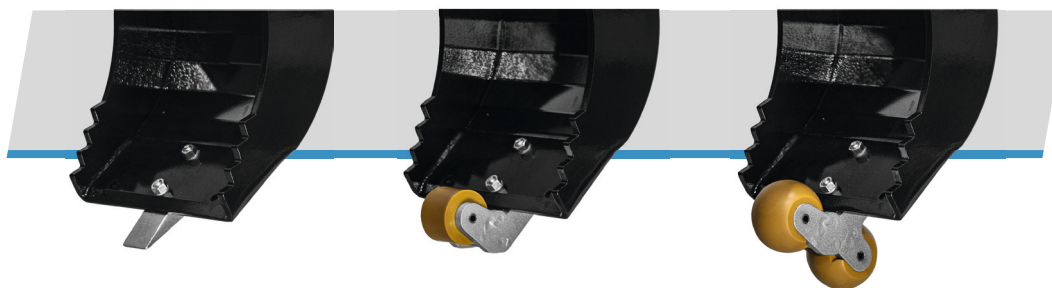

DEMOLITION GRAB 1-22T with patented cylinder design

DMS
DMS Technologie GmbH

Available accessories

- / Softgrip in combination with tooth set
- / Pipegrip in combination with tooth set
- / Change tooth set
- / Further screw adapters on request
- / Adapter flange for personalized solution

Scope of delivery

- / Grab with rotator
- / Screwed cutting edge

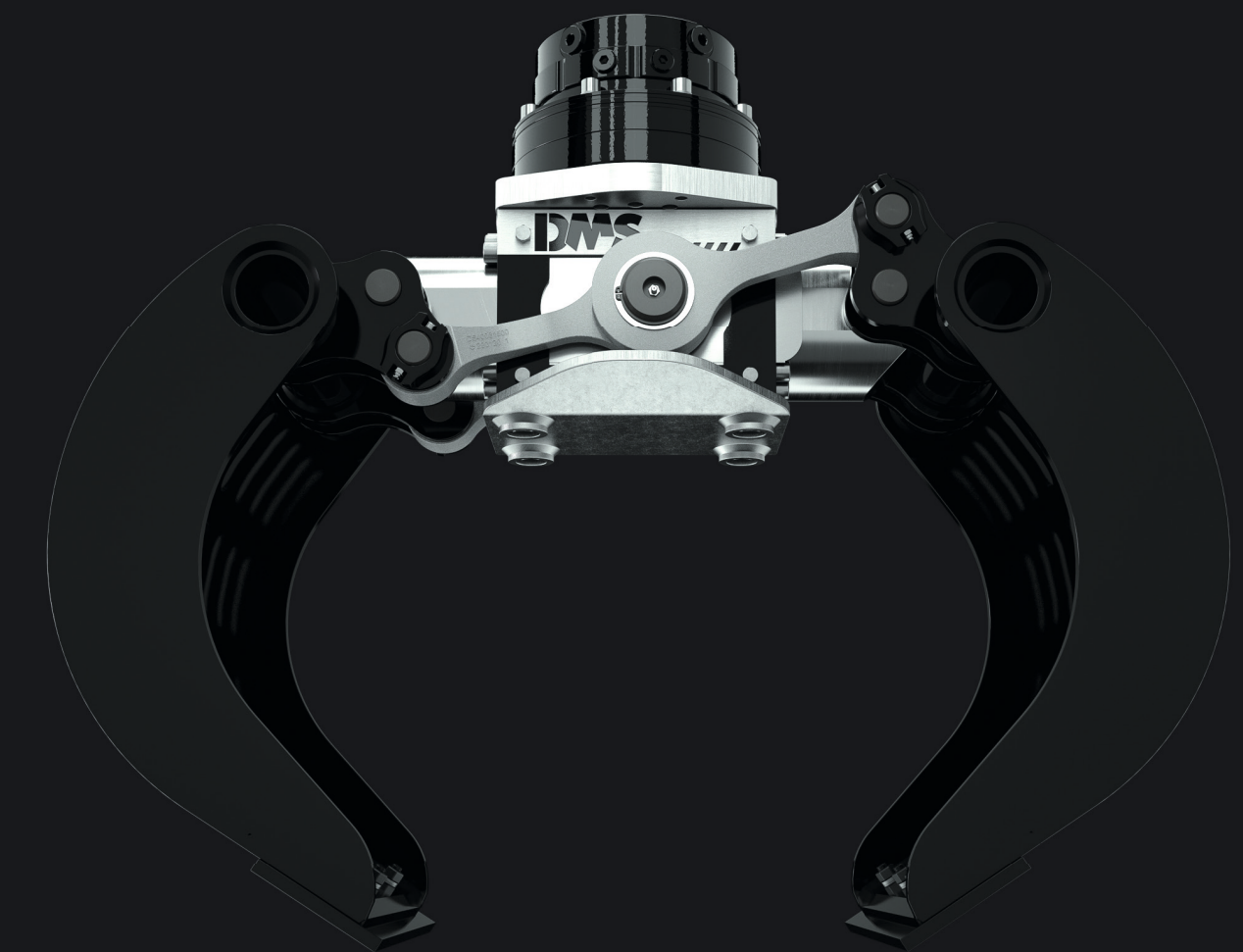

Your DMS distributor:

01/2024

DMS Technologie GmbH

Imprint:
Steinbacher Str. 62
64658 Fürth

While stocks last.
Errors, changes and
printing errors excepted.

MADE IN GERMANY

Phone +49 6253 / 806021-0
Fax +49 6253 / 806021-29

Email info@dms-tec.de
Web www.dms-tec.de



[dms-tec.de/en](https://www.dms-tec.de/en)



YOUR ADVANTAGES

Number 1
in the performance -
weight ratio

Intelligent design
no hoses underneath the
drive

Quality
with high reliability

Unique
cylinder drive

100% protected
piston rod

1 PROTECTED PISTON

2 Powerful rotator

3 Internal Oil Feed

4 High quality bushings with
long-term lubrication

5 Protected and easily
accessible lubrication points

6 Reversible cutting edges



Whether you are removing masonry, dismantling timber structures or sorting building materials, the indestructible demolition grabs from DMS Technologie are the ideal attachment. Some of the advantages of these grabs are their low overall height, optimized gripping space between the shells and low weight combined with extreme durability. The perfect combination is made possible by the patented hydraulic cylinder.

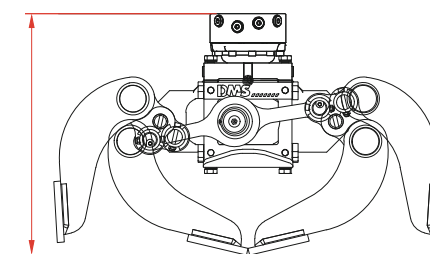

Low overall height

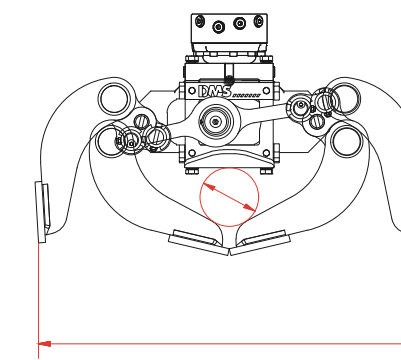

optimum gripping area

TECHNICAL DATA

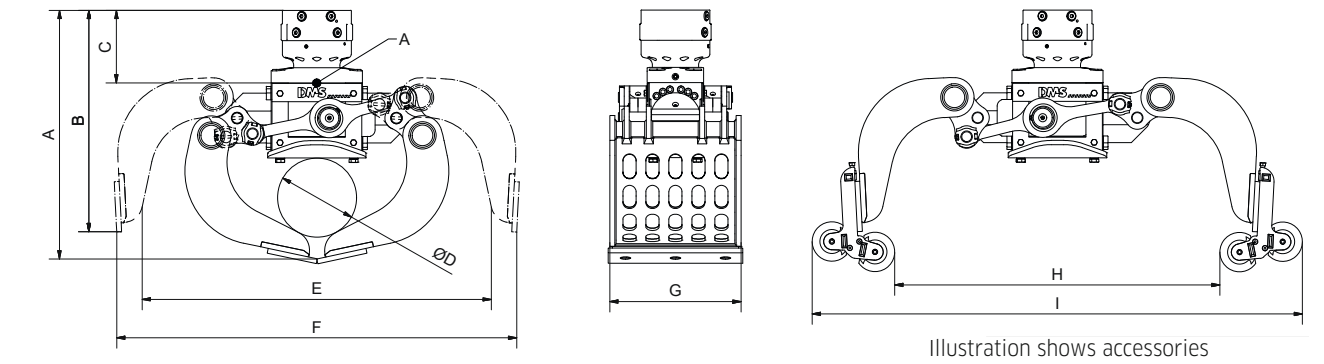

EXCAVATOR SIZE-CLASS	[T]	1-2	2-3,5	2-3,5	3,5-6	6-9	8-12	11-18	11-18	17-22
Model		AG2030	AG3535	AG3540	AG6040	AG9050	AG12060	AG18070	AG18090	AG22090
Weight (without rotator)	[kg]	98	119	199	199	334	640	743	873	906
Rotator weight	[kg]	20	29	37	52	77	88	164	164	168
Operating pressure gripping max.	[bar]	220	250	250	250	280	320	320	320	320
Operating pressure rotation max.	[bar]	220	250	250	250	280	320	320	320	320
Closing force	[kN]	16	16	20	20	26	46	50	52	52
Torque	[Nm]	1000	1200	1200	2500	3000	4200	4200	4200	4200
Capacity	[Liter]	22	55	76	76	210	264	400	562	562
Rec. litre capacity rotation	[l/min]	6-25	6-25	6-25	15-25	15-25	15-30	15-30	15-30	15-30
Rec. litre capacity gripping	[l/min]	25-40	25-45	30-45	30-45	40-80	40-150	40-150	40-150	40-150
Dimension A	[mm]	511	634	732	758	986	1149	1269	1286	1343
Dimension B	[mm]	498	560	651	675	756	1032	1124	1283	1213
Dimension C	[mm]	145	188	197	221	185	239	277	277	277
Dimension D	[mm]	Ø 128	Ø 200	Ø 241	Ø 241	Ø 438	Ø 410	Ø 477	Ø 507	Ø 507
Dimension E	[mm]	709	863	1064	1064	1550	1551	1627	1629	1629
Dimension F	[mm]	831	993	1219	1219	1734	1855	1958	1945	1945
Dimension G	[mm]	300	350	400	400	500	600	700	900	900

SOFTGRIP/PIPEGRIP

		in combination with tooth set	✓	✓	✓	✓	✓	-	-	-
Pipegrip			✓	✓	✓	✓	✓	-	-	-
Softgrip			✓	✓	✓	✓	✓	-	-	-
Number			3	3	3	3	4	-	-	-
Lifting capacity	[kg]		200	350	600	600	900	-	-	-
Dimension H	[mm]		600	750	980	980	1500	-	-	-
Dimension I	[mm]		1000	1200	1400	1400	1900	-	-	-

EXCHANGE SET

Cutting set		-	-	-	-	-	-	-	-	-
Tooth set		✓	✓	✓	✓	✓	-	-	-	-
Number of teeth in the set		3	3	3	3	5	-	-	-	-