

DEMOLITION GRAB

AG6040

DMS
DMS Technologie GmbH

TECHNICAL DATA

Excavator size-class	[t]	3,5-6
Weight (without rotator)	[kg]	199
Rotator weight	[kg]	52
Operating pressure gripping max.	[bar]	250
Operating pressure rotation max.	[bar]	250
Closing force	[kN]	20
Torque	[Nm]	2500
Capacity	[l]	76
Rec. litre capacity rotation	[l]	15-25
Rec. litre capacity gripping	[l]	30-45

TECHNICAL ILLUSTRATION

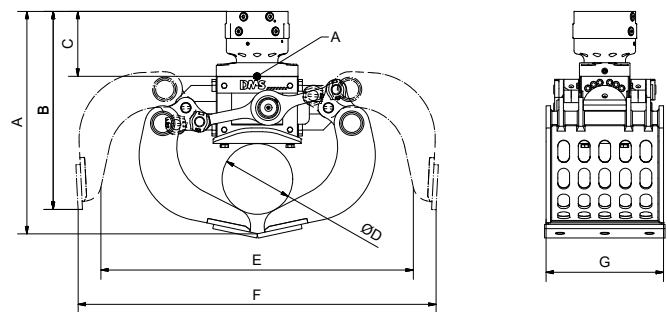

Dimension A	[mm]	758	Dimension E	[mm]	1064
Dimension B	[mm]	675	Dimension F	[mm]	1219
Dimension C	[mm]	221	Dimension G	[mm]	400
Dimension D	[mm]	Ø 241			

AVAILABLE ACCESSORIES

- / Softgrip in combination with tooth conversion kit
- / Pipegrip in combination with tooth conversion kit
- / Tooth Conversion Kit
- / Adapter for other quick coupling systems upon request
- / Adapter flange for custom solution
- / Bolt-on adapter for quick coupling system Lehnhoff MS/HS

SCOPE OF DELIVERY

- / Grab including shells
- / Bolt-on cutting edges
- / Rotator

You can find more information and a 3D preview at www.dms-tec.de

