

# DIGGING GRAB

## GL9050P

**DMS**  
DMS Technologie GmbH

### TECHNICAL DATA

Excavator size-class	[t]	6-9
Weight (without rotator)	[kg]	348
Rotator weight	[kg]	29
Operating pressure gripping max.	[bar]	280
Operating pressure rotation max.	[bar]	280
Closing force	[kN]	26
Torque	[Nm]	1200
Capacity	[l]	200
Number of teeth		5
Rec. litre capacity rotation	[l/min]	6-25
Rec. litre capacity gripping	[l/min]	40-80
Lifting capacity	[kg]	3500
Swivelling out through swinging	[mm]	1150

### TECHNICAL ILLUSTRATION

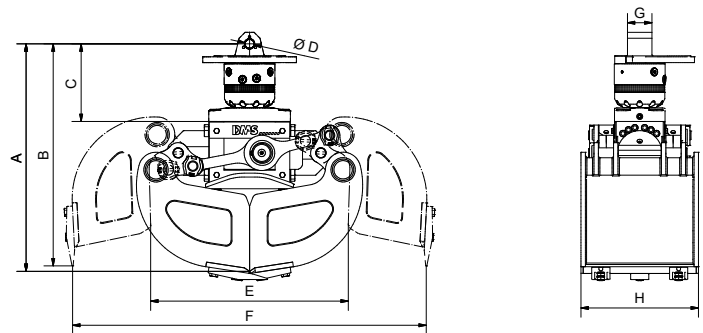

Dimension A	[mm]	1032	Dimension E	[mm]	839
Dimension B	[mm]	862	Dimension F	[mm]	1721
Dimension C	[mm]	253	Dimension G	[mm]	84
Dimension D	[mm]	30	Dimension H	[mm]	500

### AVAILABLE ACCESSORIES

- / Softgrip
- / Pipegrip
- / Pendulum mount
- / Pendulum adapter
- / Swing Damper
- / Adapter for other quick coupling systems upon request
- / Adapter flange for custom solution
- / Bolt-on adapter for quick coupling system Lehnhoff MS/HS

### SCOPE OF DELIVERY

- / Grab including shells
- / Bolt-on excavator teeth
- / Rotator

You can find more information and a 3D preview at [www.dms-tec.de](http://www.dms-tec.de)

