

DIGGING GRAB

GS10060P

DMS
DMS Technologie GmbH

TECHNICAL DATA

Excavator size-class	[t]	6-10
Weight (without rotator)	[kg]	313
Rotator weight	[kg]	29
Operating pressure gripping max.	[bar]	280
Operating pressure rotation max.	[bar]	280
Closing force	[kN]	29
Torque	[Nm]	1200
Capacity	[l]	211
Number of teeth		5
Rec. litre capacity rotation	[l/min]	6-25
Rec. litre capacity gripping	[l/min]	40-80
Lifting capacity	[kg]	3500
Swivelling out through swinging	[mm]	1330

TECHNICAL ILLUSTRATION

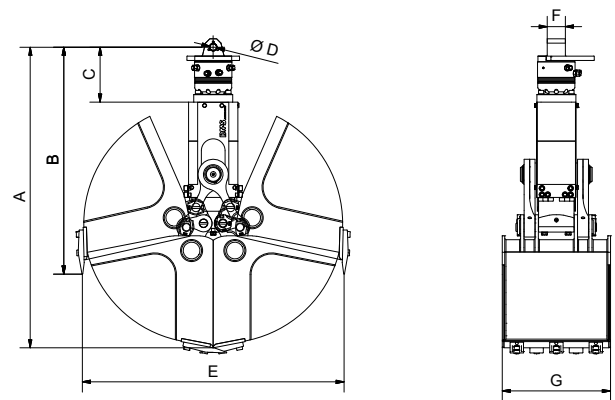

Dimension A	[mm]	1389	Dimension E	[mm]	1209
Dimension B	[mm]	1048	Dimension F	[mm]	84
Dimension C	[mm]	253	Dimension G	[mm]	600
Dimension D	[mm]	30			

AVAILABLE ACCESSORIES

- / Softgrip
- / Pendulum mount
- / Swing Damper
- / Ejector
- / Pendulum adapter for quick coupling system Lehnhoff MS/HS
- / Pendulum adapter for other quick coupling systems upon request

SCOPE OF DELIVERY

- / Grab including shells
- / Bolt-on excavator teeth
- / Rotator

You can find more information and a 3D preview at www.dms-tec.de

