

AVAILABLE ACCESSORIES

SCOPE OF DELIVERY

- / Adapter for other quick coupling systems
- / Adapter flange for custom solution
- / Bolt-on adapter for quick coupling system Lehnhoff MS/HS
- / Short tilling drum (BF3560)
- / Long tilling drum (BF35100, BF100)
- / Mudguard extension (BF35100)
- / Broom sweeper
- / Weed brushes

- / Drive unit with mudguards and selected tool

EXCAVATOR WEIGHT [t]		1-6			6-12	
Model		BF35			BF100	
Tool		short tilling drum	long tilling drum	brushes	tilling drum	brushes
Weight	[kg]	95	115	95	290	255
Dimension A	[mm]	780	780	800	1005	1015
Dimension B	[mm]	Ø144	Ø144	Ø144	Ø210	Ø210
Dimension C	[mm]	620	1020	1250	1200	1500
Dimension D	[mm]	675	1020	1020	1240	1240
Dimension E	[mm]	435	435	435	555	555
Dimension F	[mm]	Ø365	Ø365	Ø400	Ø485	Ø500
Dimension G	[mm]	255	255	255	320	330
Volume flow	[L/min]	max. 60	max. 60	max. 60	max. 125	max. 125
Operating pressure	[bar]	max. 200	max. 200	max. 200	max. 210	max. 210
Rotational speed at 30 L/min	[1/min]	130	130	130	-	-
Rotational speed at 60 L/min	[1/min]	260	260	260	-	-
Drehzahl bei 100 L/min	[1/min]	-	-	-	250	250



Your DMS sales partner:

01/2022

DMS TECHNOLOGIE GMBH

MADE IN GERMANY

Imprint:
Steinbacher Str. 62
64658 Fürth

Telephone 06253 / 806021-0
Fax 06253 / 806021-29

Errors, changes and misprints
excepted while stocks last.

Email info@dms-tec.de
Internet www.dms-tec.de/en



dms-tec.de/en



/ YOUR ADVANTAGES

ATTACHMENT FOR EXCAVATORS

replaces the hand-guided device

REDUCED RISK

of accidents milling work from the excavator cab

EXCAVATOR ARM WITH TILLER

for limited, sloping and elevated areas

THREE-IN-ONE DEVICE

for high utilization and versatile use

SEVERAL STEPS IN ONE

saves mixing of additives

This not only reduces the physical effort required for single-axle machines, but also the risk of accidents associated with hand-operated milling machines. Even confined, steeply sloping or raised areas such as noise barriers, dykes or terraced gardens are no longer a challenge for excavators with the tiller. In addition, the attachment can be quickly transformed into a weed brush for weed removal or a sweeper brush with the help of interchangeable attachments, which further increases the excavator's utilization capacity and makes the tiller a real multi-tool.

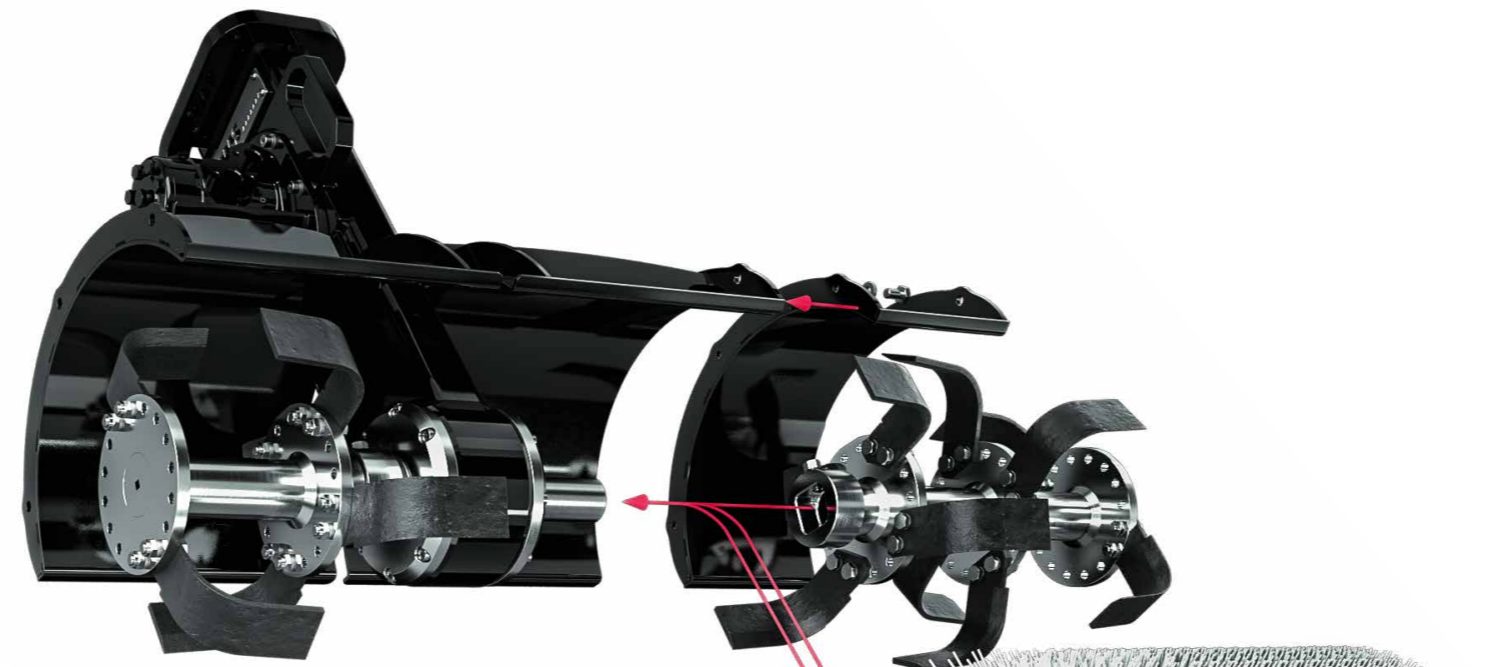

TOOL CHANGE IN ONE MINUTE

By loosening a single screw, the various attachments can be exchanged in no time at all. This means that a wide variety of jobs can be carried out with just one device, largely without interruption.



/ EQUIPMENT VARIANTS

SHORT TILLING DRUM

The short tilling drum offers a working width of 0.6 meters and is the ideal attachment for a wide range of earthworks. Loosening up soil, mature and compacted soils, incorporating additives such as humus, fertilizer or lime, mixing soils and tilling beds are just some of the many areas of application.

LONG TILLING DRUM

The long tilling drum offers all the advantages of the short tilling drum with an extended working width of one meter. The mudguard extension is required in combination with the long tilling drum.

BROOM SWEEPER

The sweeping roller enables quick and convenient cleaning of dirty surfaces. The laborious cleaning of the construction site, which usually takes a lot of time towards the end of the working day, is carried out efficiently and with ease using the sweeping roller.

WEED BRUSH

The weed brush removes unwanted vegetation mechanically. The special bristles effectively remove moss and weeds from joints, cracks, crevices and surfaces. The material mix of flat wire and plastic filaments removes weeds and cleans the surface in a single operation.

