

ROTARY TILLER

BF100 - Broom sweeper

DMS
DMS Technologie GmbH

TECHNICAL DATA

Excavator weight class	[t]	6-12
Weight	[kg]	255
Volume flow	[L/min]	max. 125
Operating pressure	[bar]	max. 210
Rotational speed at 30 L/min	[1/min]	-
Rotational speed at 60 L/min	[1/min]	-
Rotational speed at 100 L/min	[1/min]	250

Dimensions in mm

TECHNICAL ILLUSTRATION

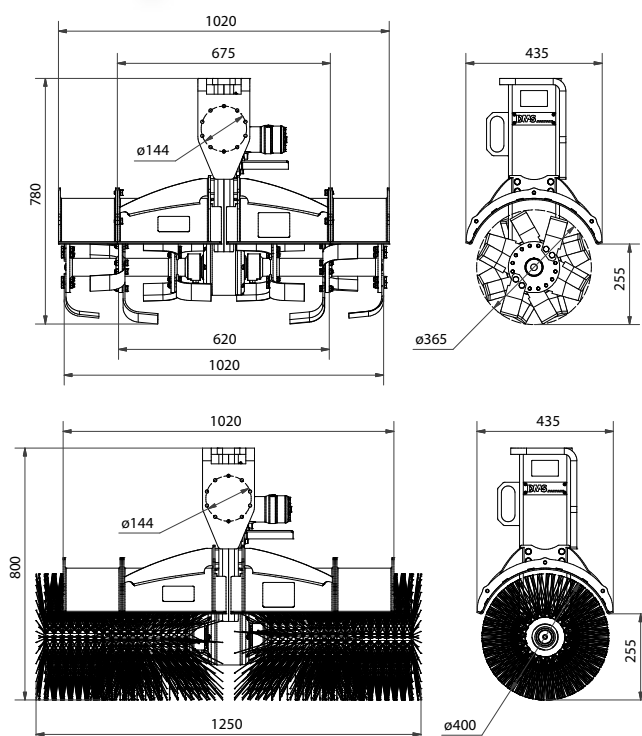

AVAILABLE ACCESSORIES

- / Bolt-on adapter for quick coupling system Lehnhoff MS/HS
- / Adapter for other quick coupling systems upon request
- / Adapter flange for custom solution upon request
- / Hydraulic hoses set
- / More tools (tilling drum, broom sweeper)

SCOPE OF DELIVERY

- / Drive unit including guard plates and selected tools

You can find more information and a 3D preview at www.dms-tec.de

