

# ROTARY TILLER

## BF35 - Short tilling drum

**DMS**  
DMS Technologie GmbH

### TECHNICAL DATA

|                               |         |          |
|-------------------------------|---------|----------|
| Excavator weight class        | [t]     | 1-6      |
| Weight                        | [kg]    | 95       |
| Volume flow                   | [L/min] | max. 60  |
| Operating pressure            | [bar]   | max. 200 |
| Rotational speed at 30 L/min  | [1/min] | 130      |
| Rotational speed at 60 L/min  | [1/min] | 260      |
| Rotational speed at 100 L/min | [1/min] | -        |

Dimensions in mm

### TECHNICAL ILLUSTRATION

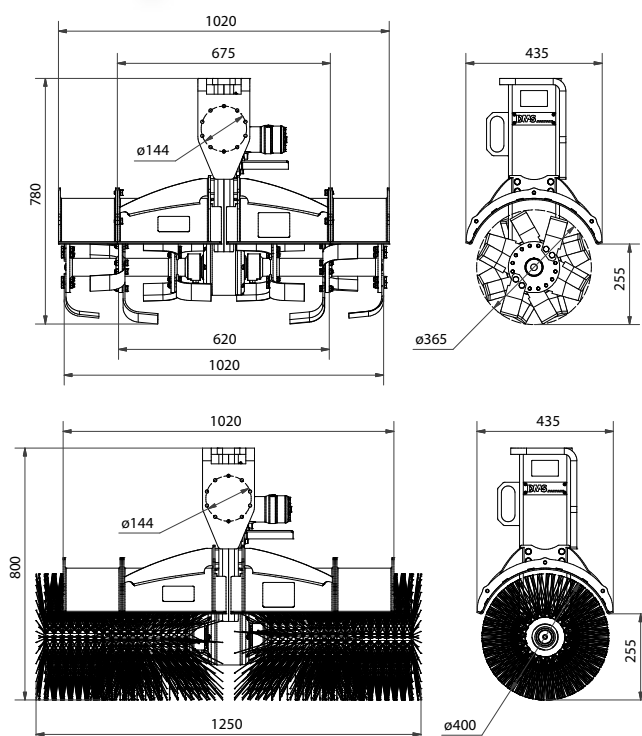

### AVAILABLE ACCESSORIES

- / Bolt-on adapter for quick coupling system Lehnhoff MS/HS
- / Adapter for other quick coupling systems upon request
- / Adapter flange for custom solution upon request
- / Hydraulic hoses set
- / More tools (long/short tilling drum, broom sweeper, weed brush)

### SCOPE OF DELIVERY

- / Drive unit including guard plates and selected tools

You can find more information and a 3D preview at [www.dms-tec.de](http://www.dms-tec.de)

